

NEXEO | HDX™ Crew Communication Platform QUICK REFERENCE INSTALLATION GUIDE

- 1** Before you begin, survey the premises with the store manager to determine the best mounting locations for each component. Take into consideration:
- The NEXEO® system requires a region code to function, so an internet connection and an HME CLOUD account are necessary. Connect and verify the RT7000 before installing it.
 - Cable lengths for the hardwired components.
 - Proximity to power outlet and network router.
 - Base station accessibility to all crew members and in an area free from obstructions.
 - The base station mounting height should be 5 feet (1.52 m), see Fig. 1.1.
 - Choosing a good RT7000 (transceiver) mounting location is critical (see Step 5, Fig. 1.3, 1.4, and Component Notes on page 3 for more details). See page 4 for the required tools/equipment.

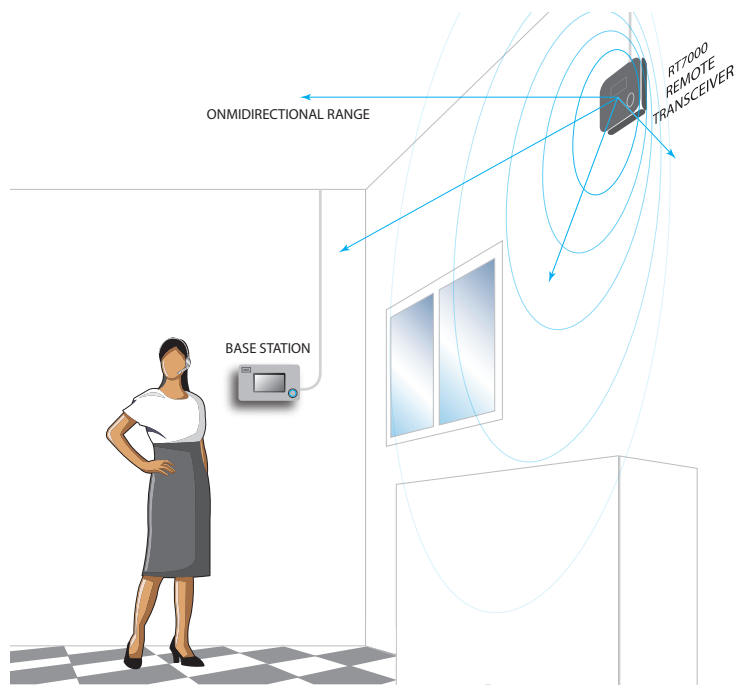

Fig. 1.1

- 2** Set up and connect the AC70 battery charger to power. Insert BAT70 batteries to begin charging. Up to four batteries can be charged at once. See "Component Notes" on page 3 for more information.

- 3** If you are replacing an existing HME product such as EOS®, and mounting the base station close to the location of the base station you are replacing, you may be tempted to reuse the existing wires/cables without rerouting new ones. However, the customer has purchased a new system that requires routing new cables. Open the base station and mark the mounting location on the wall using the four mounting holes at each corner (see Fig. 1.2). Mount the base station using the provided hardware.

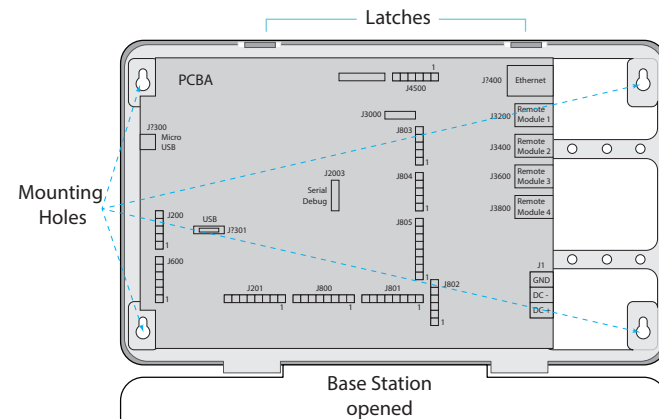

Fig. 1.2

- 4** Mount the base station power supply. Mark the mounting location on the wall through the mounting holes. Mount the power supply using the hardware provided.
- 5 Critical Step:** Loosely mount the RT7000 in a central location for optimal coverage (until range tested in steps 9 & 10 using the Installation Wizard). For example, notice Fig. 1.3 and 1.4. They show two different store layouts with specific targeted areas where the headsets are primarily used. In these examples, the location selected for the RT7000 (represented by the small blue rectangle) provided the best coverage, indicated by the blue-circled areas. Each store required the RT7000 to be mounted in a different, yet central, location to provide the best all-around coverage tailored to the store's needs. Store layout and obstructions also affected placement and range. (see "Component Notes" on page 3 for more details on the RT7000 placement).



CAUTION: If the RT7000 needs to be relocated, wait at least 5 seconds after unplugging it before reconnecting the cable to the same base station port, or use a different base station port.

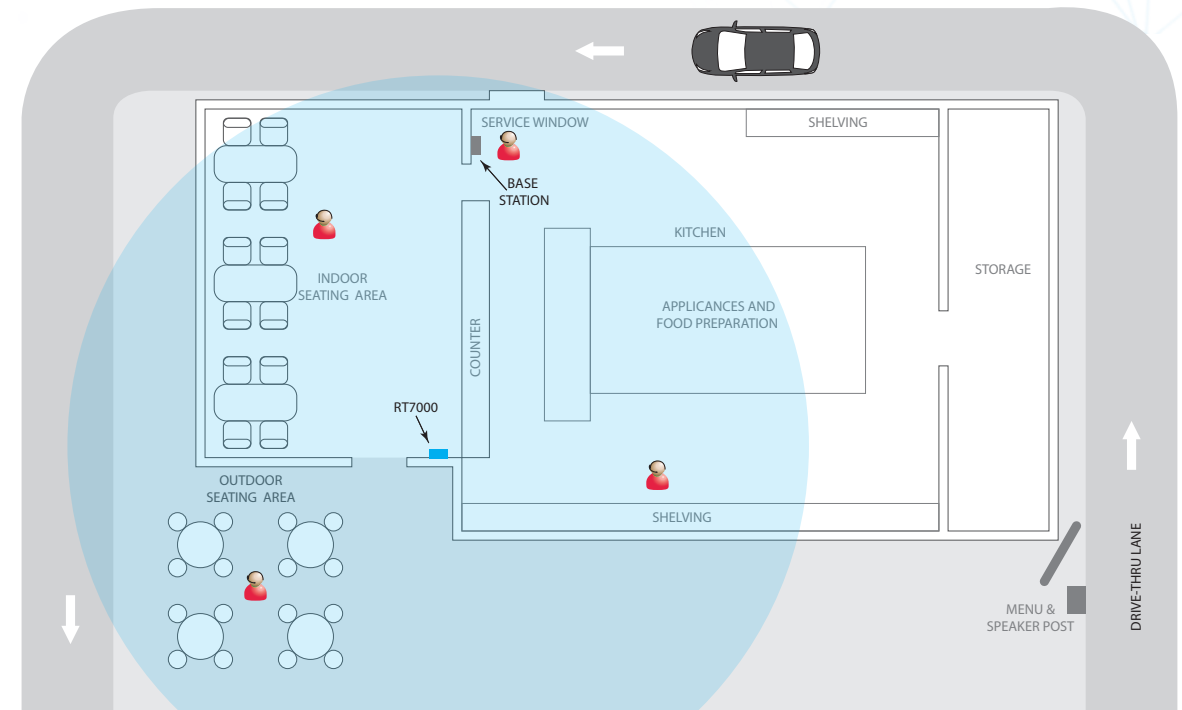

Fig. 1.3

Personnel with headsets

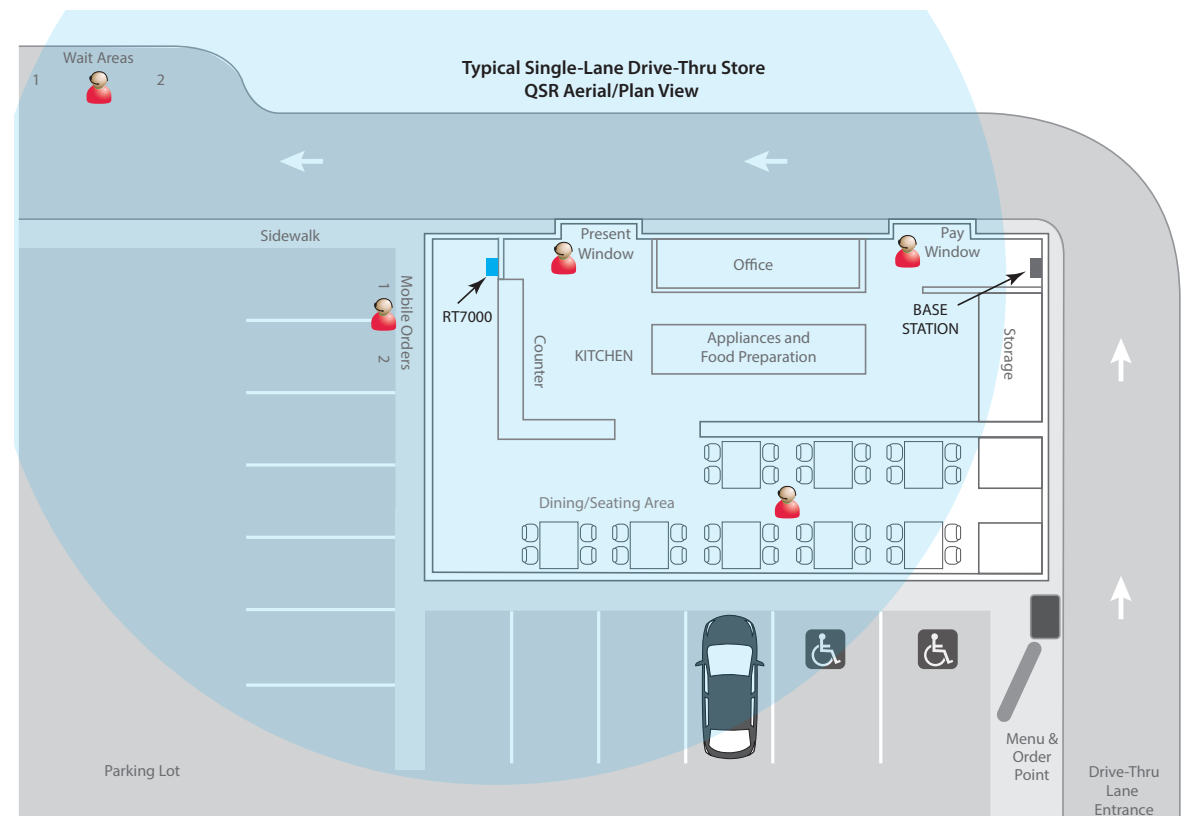

Fig. 1.4

- 6 Install the other components. The SS7000 (or SP10) speaker & DM5 microphone must be installed using the IB7000. See Fig. 2.3 and “Component Notes” on page 3, or Fig. 4.2 on page 4 if using the SP7000 & DM5 (does not require IB).
- 7 Route and terminate all additional component cables to the base station using the wiring references in this guide. Consult the store’s IT personnel when connecting to the network router.
- 8 Terminate the base station power supply and connect to outlet. The base station turns on.
- 9 On the base station UI, follow the onscreen Installation Wizard to configure and test the system.

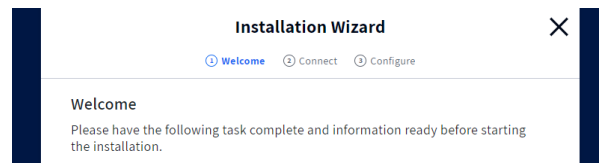

Fig. 2.1

Note: If you accidentally exit the Installation Wizard and need to return to it. LOG IN to the system, go to SYSTEM, then the TROUBLESHOOTING tab, and select “Installation Wizard” from the drop-down list. Tap the “Start Installation Wizard” button.

- 10 **Critical Step:** The Installation Wizard will prompt you to use a paired headset switched to Reception Location Mode. You will need to walk all areas of the store where the headset will be used to ensure a good signal. The Boom LED at the tip of the Headset microphone flashes different colors to indicate areas with a strong or weak reception. See Fig. 2.2. Also see CAUTION Note in Step 5.

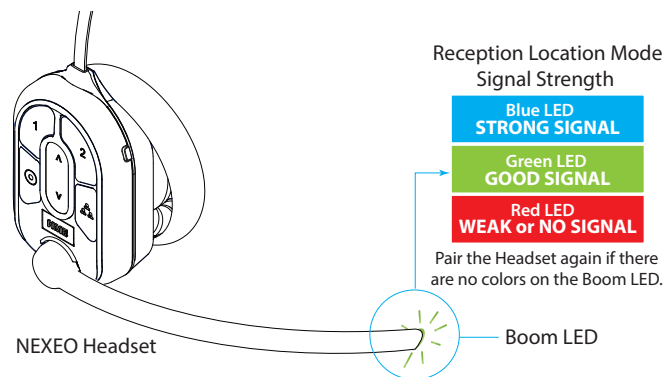

Fig. 2.2

Note: Depending on the store’s size and layout, some stores may require more than one RT7000 to achieve good coverage.

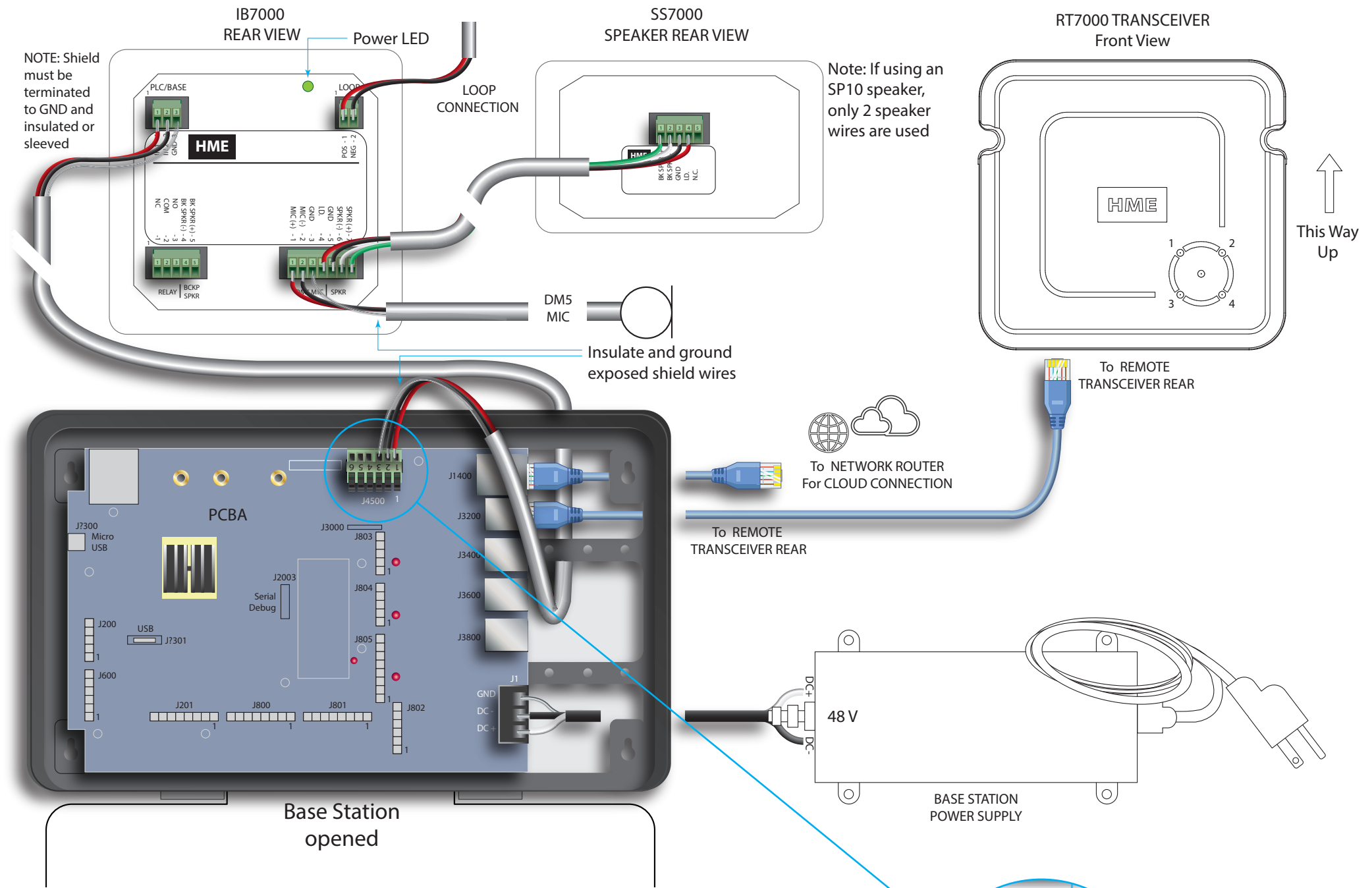

Fig. 2.3

- 11 Once the optimal location for the RT7000s has been verified, secure all the loosely mounted system components.
- 12 Test audio levels between the headsets and the drive-thru ordering points, adjust accordingly using the volume controls on the base station UI.

- 13 Use cable ties to bundle and strain relief the cables exiting the base station to one of the cross-bars on the rear housing.
- 14 Close the base station. The system is now ready for use.

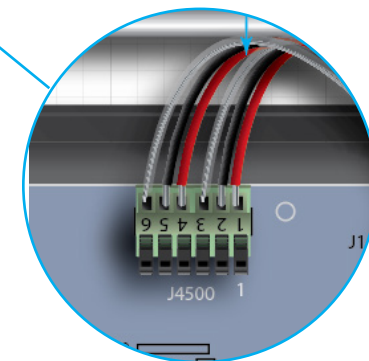

Fig. 2.4

J4500 Detail: Fig. 2.3 shows the connections for a single-lane drive-thru. Fig. 2.4 shows the connections for a dual-lane drive-thru.

COMPONENT NOTES

Installing the RT7000:

- The RT7000 is omnidirectional so mount it high in a central location where the headsets are typically used.
- Maximize line of sight between the RT7000 and headsets in an area free from obstructions and equipment/materials that can interfere with signal propagation. These include walls, large metal appliances, hoods, and backsplashes, etc.
- Mount the RT7000 vertically on a wall in the upright position (see arrow on RT7000 rear). Do **NOT** mount horizontally, such as on a ceiling. This will reduce the RT7000's range.
- The RT7000 uses an Ethernet cable (Cat5 or Cat6). Do not exceed 500' (152 m).
- Large or multilevel premises may require more than one RT7000. Up to four RT7000s are supported by the base station (J3200-J3800).
- Once connected to the base station, the center LED on the RT7000's front panel illuminates to indicate it is turned on. One of the outer LEDs (numbered 1 to 4) also turns on depending on what base station port it is connected to (1 is used in this example). This outer LED will initially flash a different color as the RT7000 scans for available channels, then turn solid green once a channel is found (on the base station HOME screen, the "Transceivers" indicator is yellow while scanning before turning green).
- A surge protector/lightning arrestor is recommended if mounting outside on an exterior wall. Contact HME if one or more are required.

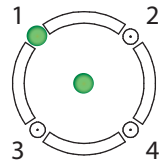

Base Station Power Supply:

- Terminate the positive wire of the power supply to J1 DC + terminal (pin 1).
- Terminate the negative wire of the power supply to J1 DC - terminal (pin 2).
- Terminate the shield to J1 GND (pin 3).

Note: Only use the HME power supply provided with your system.

IB7000 Connections:

The IB7000 must be mounted vertically, inside the speaker post, close to the speaker/microphone. This will help minimize audio hum and noise. Adhesive strips on housing allow the IB7000 to be affixed to a clean, dry surface inside the speaker post. All connectors are labeled. The max IB7000 cable length to guarantee operation at max volume should not exceed 500 ft (152 m). The IB7000 green power LED illuminates when the base station has power.

- The two-pin Loop connector connects to the ground loop detector.
- The three-pin PLC/BASE connector connects to J4500 on the base station. **Note:** The shield/drain must be grounded.
- The seven-pin DM5 MIC | SPKR connector connects to the Microphone and Speaker. **Note:** Pins 4 and 5 are only used if connecting the SS7000.
- The five-pin RELAY | BCKP SPKR connector (optional) connects to an intercom system such as the IC300 if a backup is needed in the event of a system failure.

Note: If installing more than one IB7000. Take note of the serial numbers, so you know where each one is assigned when configuring using the base station.

Installing the Weather Cover

The weather cover **must** always be attached to protect the electrical connections from water ingress. First, attach the top latch over the IB ridge and housing seam. Then, hinge the bottom latches onto the IB bottom. Ensure the cables exit the bottom opening. Press the cover onto it to snap it securely in place.

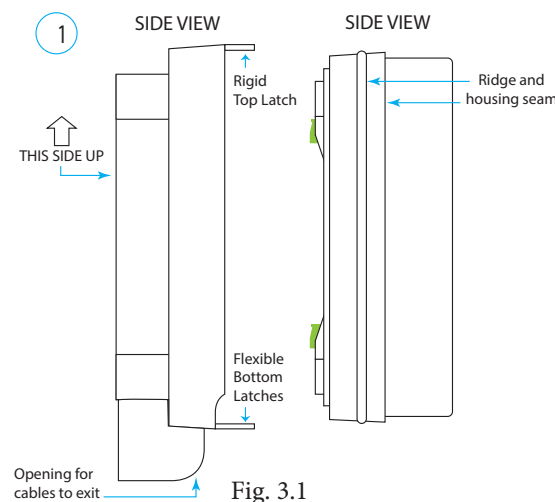
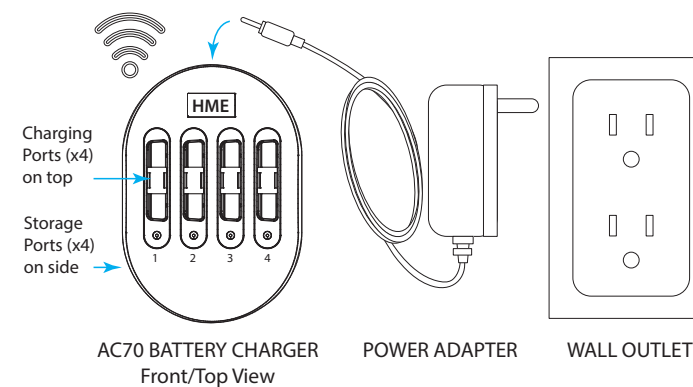

Fig. 3.1

The AC70 Smart Battery Charger:

- The AC70 can be placed on a desk or mounted on the wall (use template on page 4 for wall mounting). Position the AC70 within 10 feet (3 m) of the base station to monitor your battery status on the base station HOME screen.
- New BAT70 batteries must be charged, so begin charging them immediately. The BAT70 battery is keyed so it can only be inserted one way. Do not force fit.
- The LEDs on the AC70 indicate charge status (see AC70 LED Reference Table). Or, if placed within range of the base station, the status indicator will turn ● (green). Tap the **Chargers** tile on the HOME screen to view battery status. **Note:** If the Chargers status indicator on the Home screen is ● (gray), the AC70 is not detected and out of range. Move it closer until the indicator turns green (it may take a moment to update).

AC70 LED Reference Table		
	Color	Status/Description
	Green	Flashing = Charging Solid = Fully charged
	Red	Flashing = Incompatible battery
	Red/Yellow	Flashing Red & Yellow = Fault condition



Note: Only use the HME approved Power Adapter provided. Storage ports do not charge batteries.

Fig. 3.2

Headset:

- Install a charged BAT70 battery into the headset. It powers on when using HS7100* or press the power button to turn on when using HS7000 (Fig. 3.3). The LEDs flash green and red.
 - Pair the headset by holding the headset's keypad side against the Headset Pairing Ring (solid blue circle) on the base station (see Fig. 3.4). Pairing begins automatically as soon as the headset is sensed.
 - When the Headset LEDs stop alternating red and green, and the status LED turns solid green, pairing is successful. If pairing fails, see note.
 - Choose your position on the base station Home screen and begin using the headset.
- * The HS7100 enters sleep mode when inactive. Move it to wake it up.

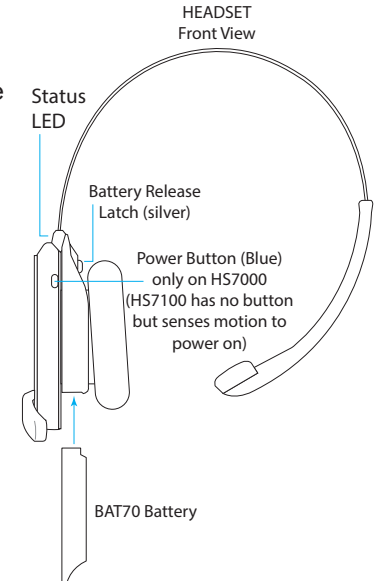

Fig. 3.3

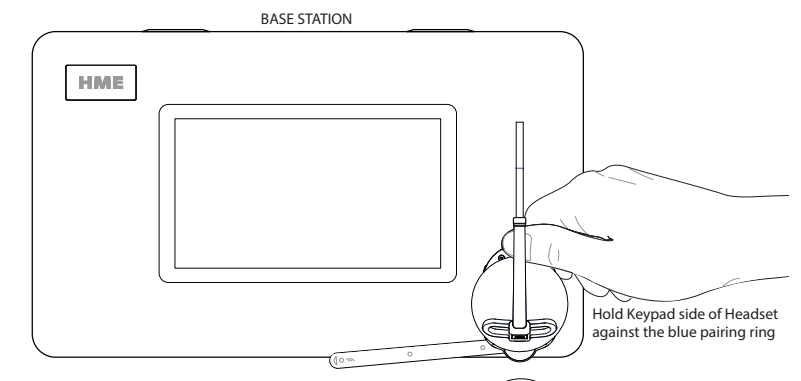

Fig. 3.4

Note: If pairing fails, try again. Hold the headset steadily centered and flush against the Headset Pairing Ring (headset movement and distance from the Pairing Ring can cause pairing errors).

A copy of this guide and much more can be found under NEXEO HDX by scanning this QR code. or going to: <https://www.hme.com/qsr/drive-thru-user-manuals/>

HME ELECTRONICS, INC.

2848 Whiptail Loop, Carlsbad, CA 92010 USA. Phone: 1-800-848-4468 | Fax: 858-552-0172
Website: www.hme.com | Email: support@hme.com



J600 (Ceiling Speakers)		
Pin #	Label	Description/wire color
1	Ceiling Spkr1 +	Speaker 1 positive
2	Ceiling Spkr1 -	Speaker 1 negative
3	GND	Ground
4	Ceiling Spkr2 +	Speaker 2 positive
5	Ceiling Spkr2 -	Speaker 2 negative
6	GND	Ground

J4500 (Spkr/Mic Interface)		
Pin #	Label	Descrptn/color
1	Spkr/Mic PL +	Red to PLC IN1 - 1 (Lane 1)
2	Spkr/Mic PL -	Black to PLC IN2 - 2 (Lane 1)
3	Shield	Shield to PLC GND - 3 (Lane 1)
4	Spkr/Mic PL +	Red to PLC IN1 - 1 (Lane 2)
5	Spkr/Mic PL -	Black to PLC IN2 - 2 (Lane 2)
6	Shield	Shield to PLC GND - 3 (Lane 2)

J803 (Early Warning Inputs)		
Pin #	Label	Description/wire color
1	Erly Wrn In 1	Early Warn In 1
2	GND	Ground
3	N/C	Not connected
4	Erly Wrn In 2	Early Warn In 2
5	GND	Ground

J201 (Telephone Interface)		
Pin #	Label	Description/wire color
1	Tel Audio In	
2	Tel Power +12V	
3	Tel Off Hook	
4	Tel PTT	
5	Tel Ring	
6	Tel Active	
7	Tel Ground	
8	Tel Audio Out	

J804 (Remote Switch Inputs)		
Pin #	Label	Description/wire color
1	GND	Ground
2	OO in 1	Outside Order in 1
3	Ded in	Dedicated In
4	OO in 2	Outside Order in 2
5	GND	Ground

J800 and J801 (Lane 1 & 2 Timer)		
Pin #	Label	Description/wire color
1	Greet Out (Analog)	Greet Out 1 for J800 Greet Out 2 for J801
2	GND	Ground for J800 and J801
3	N/C	Not connected
4	Alt Grt Out (Digital)	Alt Greet Out 1 for J800 Alt Greet Out 2 for J801
5	GND	Ground for J800 and J801
6	Veh Det Out Com	Veh Det Out Com1 for J800 Veh Det Out Com2 for J801
7	Veh Det Out N.O.	Veh Det Out N.O.1 for J800 Veh Det Out N.O.2 for J801
8	Veh Det Out N.C.	Veh Det Out N.C.1 for J800 Veh Det Out N.C.2 for J801

J805 (Alert/Alert Switch Inputs)		
Pin #	Label	Description/wire color
1	Switch In 1	
2	Switch In 2	
3	Switch In 3	
4	GND	Ground
5	Switch In 4	
6	Switch In 5	
7	Switch In 6	
8	GND	Ground

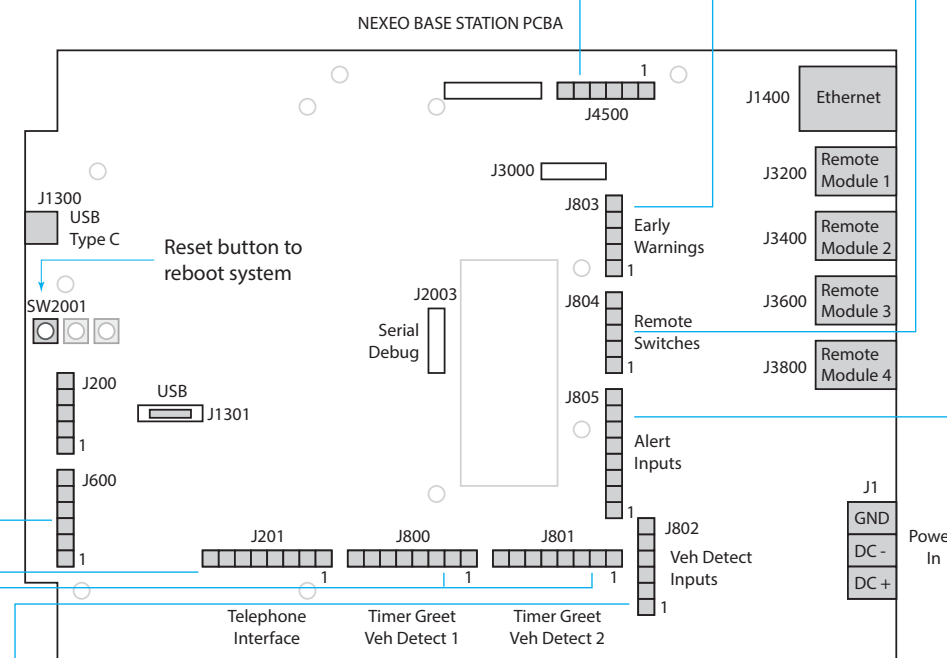

Fig. 4.1

J802 (Ext. Vehicle Detect Inputs)		
Pin #	Label	Description/wire color
1	+12 V	Power
2	N/C	Not connected
3	Veh Det In 1	Vehicle Detect In 1
4	GND	Ground
5	Veh Det In 2	Vehicle Detect In 2
6	GND	Ground

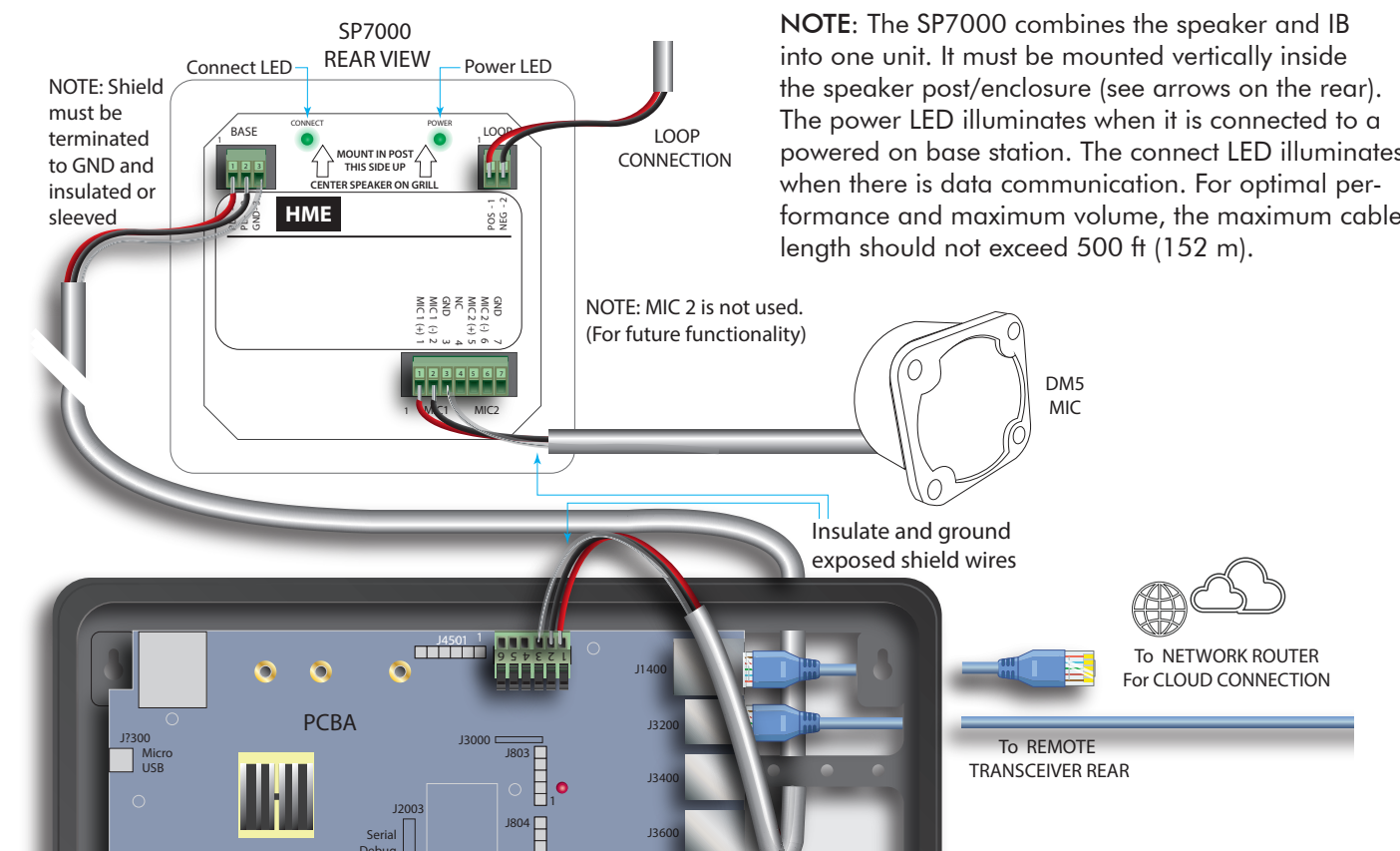

Fig. 4.2

- Tools/Equipment Needed**
- General hand tools: Screwdrivers, cutters, pliers, wire strippers, etc.
 - Drill and drill bit set
 - Tape measure, pencil/maker
 - Cable Pull Equipment (fish stick/tape, pull string, cable ties, etc.)
 - Soldering Iron and solder.
 - Crimp caps or shrink tubing with heat gun
 - Serrated knife
 - Safety glasses, ladder
 - Acoustic Foam
 - Audio Cable

- Mounting Template for AC70**
1. Hold template against wall,
 2. Use a marker to punch through paper at the crosshairs to mark the wall.
 3. Mount using hardware provided (leave a small gap between the screw head and the wall so that the AC70 keyholes mount over the screw heads, flush to the wall).

